

Schutzvermerk ISO 16016 beachten. The reproduction, distribution and utilization of this document as well as the communication of its contents to others without explicit authorization is prohibited. Offenders will be held liable for the payment of damages. All rights reserved in the event of the grant of a patent, utility model or design.

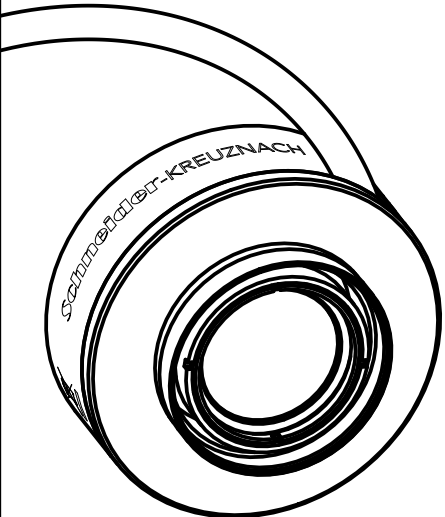
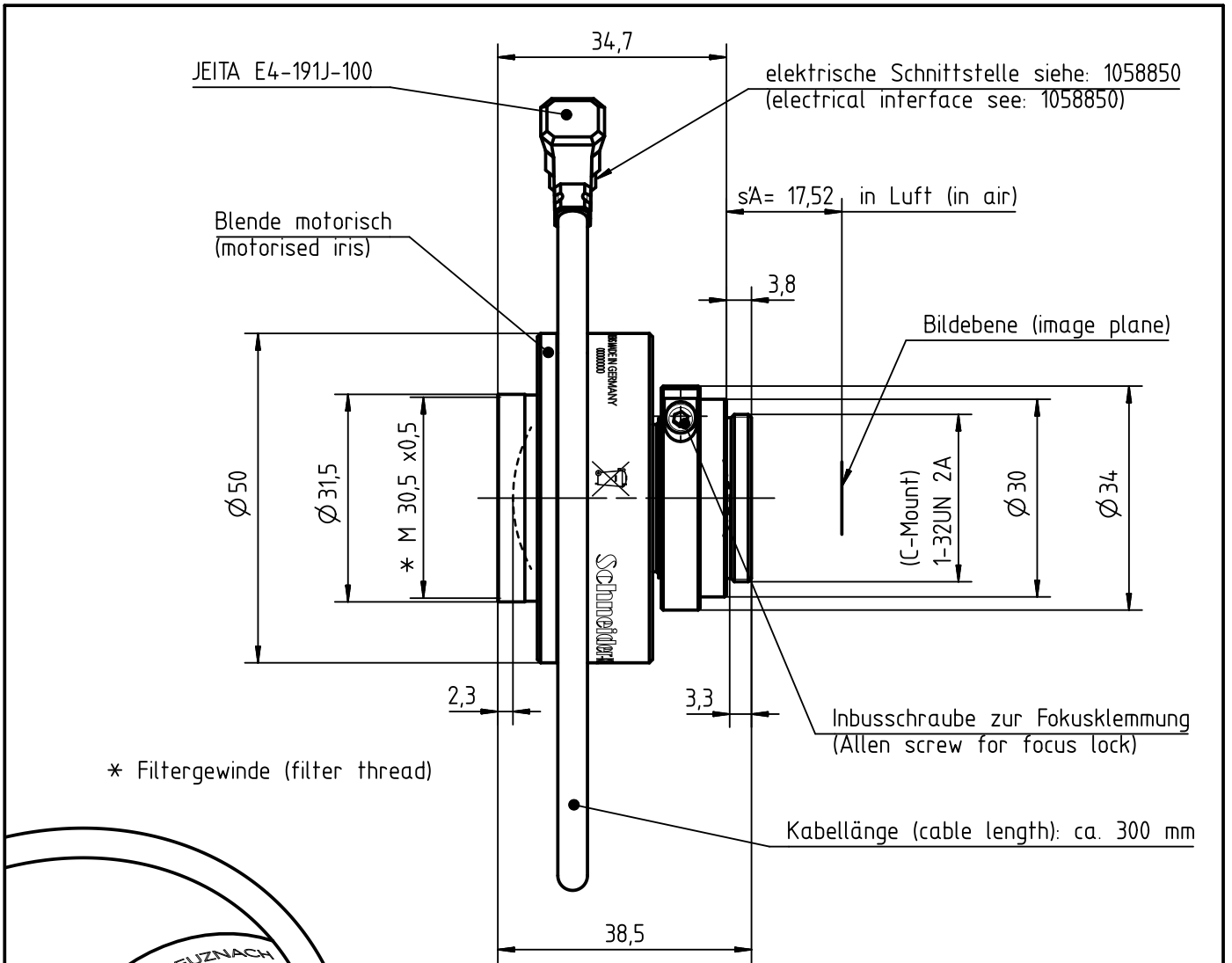

Motorschritte (motor steps)	7	8	13	18	24	29	35	36
Blenden-Ø (iris-Ø)	9,6	9,0	6,6	4,8	3,3	2,4	1,6	1,5
Blendenzahl (f-stop)	1,9	2,1	2,8	3,9	5,6	7,9	11,2	12,0

Blendenzahl (f-stop)	1,9	2	2,8	4	5,6	8	11
Blenden-Ø (iris-Ø)	9,8	9,3	6,6	4,7	3,3	2,3	1,7
Motorschritte (motor steps)	6,7	7,5	13	18,4	24	29,3	34,8

Optische Grunddaten (optical Data)

f'	34,93	s'_{AP}	-13,55	Blendenbereich (iris range)	-
$s'_{F'}$	17,03	β' Bereich (β' area)	-	Blendendurchmesser Nennwert (aperture diameter nominal)	-
$s'_{H'}$	-17,90	β'_p ($\beta' = 0$)	0,87		
HH'	-13,40	$00'$ ($\beta' = 0$)	∞	Sonstige Angaben (other information)	
$S_1 S_k$	32,90	s ($\beta' = 0$)	∞	Schutzkappe vorn (front lens cap)	30373
s_{EP}	33,37	s'_k ($\beta' = 0$)	17,03	Schutzkappe hinten (rear lens cap)	30422
Bildkreis (image circle)			11	Gewicht (weight)	136g
Angaben ohne Einheiten in mm (all dimensions without unit in mm)				Bestell- Nr. (order-no.)	1061453

Datum (date) 29.01.13

Nur zur Information (only for information)

Freigabe (release)	
R & D	<input checked="" type="checkbox"/>
Production	<input checked="" type="checkbox"/>
Sales	<input checked="" type="checkbox"/>
VT	<input checked="" type="checkbox"/>

XENOPLAN 1,9/35-1901
 Jos. Schneider Optische Werke GmbH
 Ringstr. 132 55543 Bad Kreuznach
 Germany

